

# CITRUS JUICE EXTRACTOR EXZEL



## DEVICE APPLICATION

NFC and concentrate citrus juice extraction with membranes and fibers line separation system of the juice. Device ready to recover the essential oil of peel in independent processes.

## DEVICE DESIGN

Cups extraction system adaptable to the size of fruit. Active feeding system to guarantee the highest efficiency incorporated at the reception with motorvibrador to ensure optimum feeding. Separation system of oil contained in the peel. Active and supervised lubrication system. Hardened cam drive security system monitoring overexertion in extraction elements, feeding and stop-motion. Optional CIP spray cleaning system. Structure and elements in contact with the juice made of stainless steel and alimentary materials.

## TECHNICAL INFORMATION

Cycles per minute	85 – 100
Fruit Sizes	2", 2 - 3/8", 3", 4" y 4 - 1/4"
Production capacity	1.500 lts/h juice (approx.)
Juice tank Connections	Link NW 50 x2
Essential oil recovery system connection	Male thread G3/2"
Essential oil recovery system flow	1.000 / 1.800 lts/h
CIP Connection	Male thread G1/4"
Pneumatic Connection	Fast fittingg Ø10
Power	11.5 Kw
Weight	1.700 kgs

## DIMENSIONS

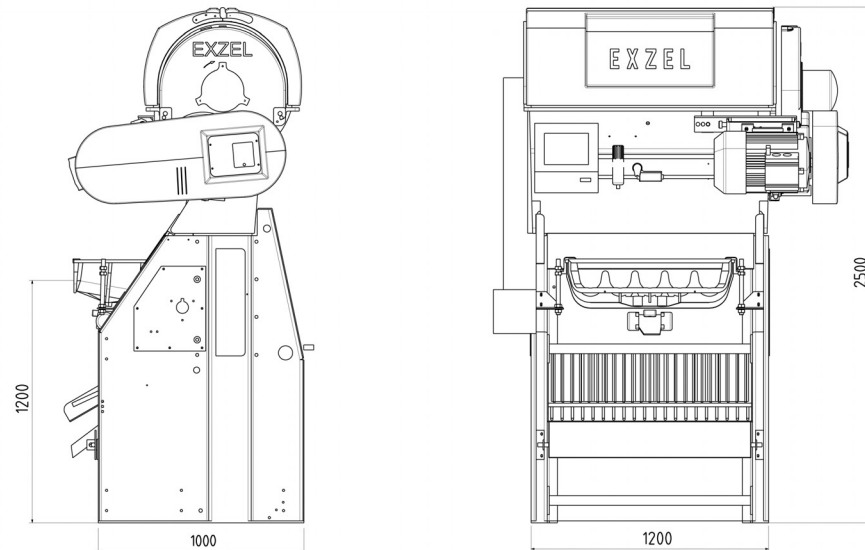

# CITRUS JUICE EXTRACTOR EXZEL



## PRODUCTS

Design, construction, installation, starting and maintaining of machines, extraction facilities and juice processing, fully contrasted, reliable and safe, adapted to the needs of customers through constant innovation based on our experience, incorporating new materials and technologies to our products.

## SERVICES

Technical service, application spare parts, technical information, training.

INDUSTRIA DE MAQUINARIA LUZZISA S.L Pol. Ind. Nº7 C/Les Rotes, 9 46540 EL PUIG  
Tlf(34)961445678 Fax (34)961443718 [www.luzzysa.com](http://www.luzzysa.com) [exzel@luzzysa.com](mailto:exzel@luzzysa.com)

Citrus juice extractor line type, made in a single operation the extraction of juice and essential oil without contact between them, obtaining a pure flavor and protecting the quality of the juice.



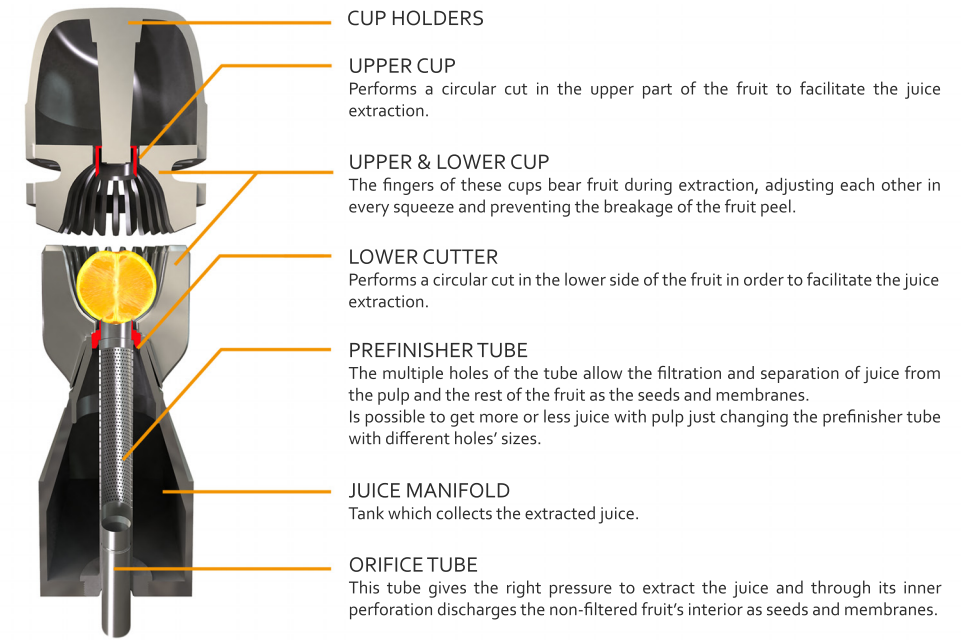
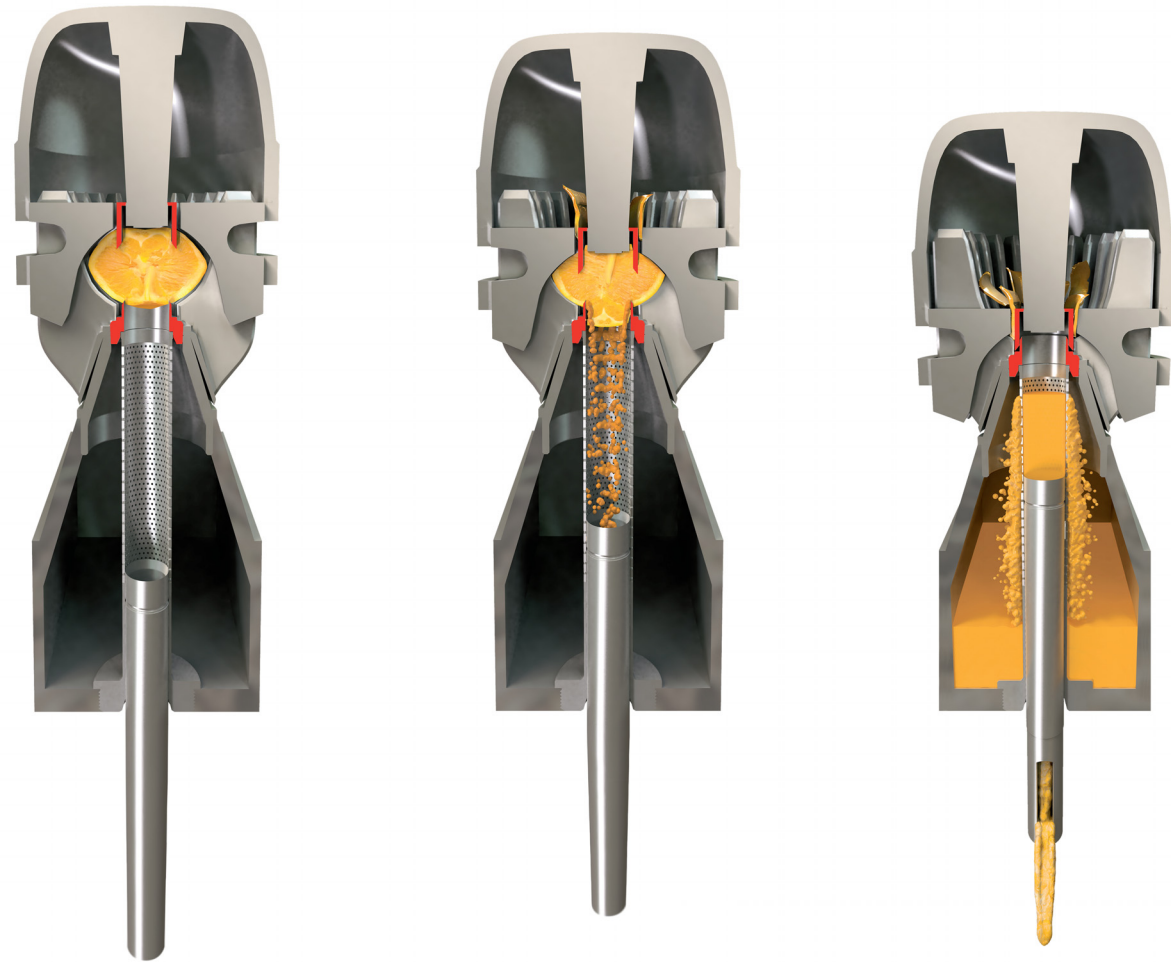

**STEP 1**  
Cup upper and lower interlocking capturing the fruit that is pressed against the cutters located in the upper and lower zone performing a circular cut at each end. The cutters prevent intrusions of essential oil during squeezed.

**STEP 2**  
The pressure around the fruit increases with advancing of the upper Cup and force its content out through the lower cutter entering into the filter tube. Simultaneously, the peel is expelled through the fins of the cups and a sprinkler system carries the essential oil.

**STEP 3**  
The piston ascends inside the filter tube provided with multiple holes, pressing the interior of the fruit that enclose the juice to flow until the juice box. Seeds, pressed membranes and the remaining fibers are expelled through the inner hole of the piston.

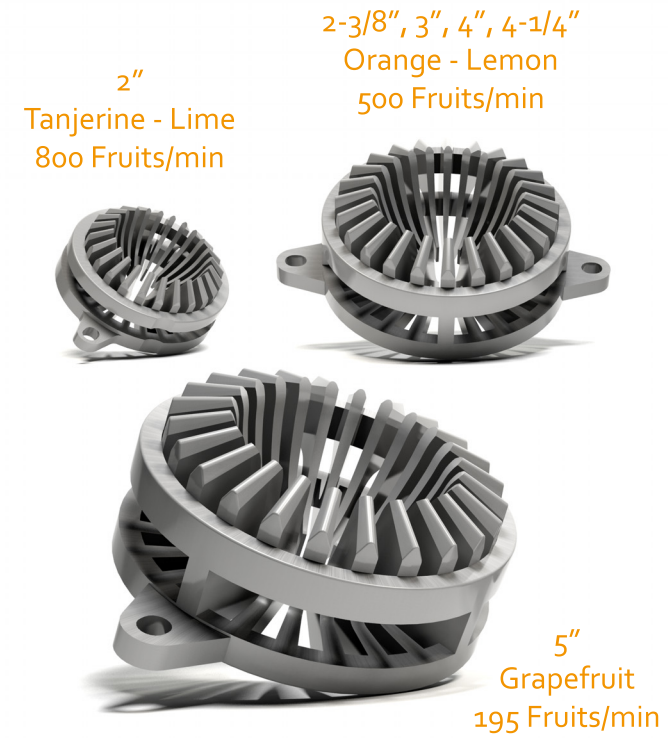

Instantaneous separation of juice and essential oil .

Configuration adaptable to the size of fruit.

